

OBSOLETE:

FOR INFORMATION PURPOSES ONLY

Contact Linear Technology for Potential Replacement

FEATURES

- Micropower Operation ($I_Q = 20\mu\text{A}$)
- Adjustable Regulator for Battery Charging
- 4.85V Regulator for Battery Regulation
- Cell Voltage Equalization in 2-Cell Systems
- Low-Battery Detector Protects Lithium Cells
- Comparator for Automatic Power Switching
- Shutdown
- Output Current Sensing
- Current and Thermal Limiting
- Reverse Output Protection
- 16-Pin SO Package
- Operates on 7V to 30V Input

APPLICATIONS

- Backup Battery Management Systems for Portable Computers
- Lithium-Ion Backup Systems
- NiCd Backup Systems

DESCRIPTION

The LT[®]1239 is a micropower backup battery management system for portable computers and instrumentation. It contains two regulators for regulating the battery voltage and memory voltage and a comparator for switching between main power and backup power. The first regulator provides a constant voltage charge for the backup batteries and is adjustable from 3.75V up to 20V. An equalization amplifier combined with the first regulator provides precision charge equalization for a 2-cell lithium-ion system. A second regulator with 4.85V output provides a regulated backup battery voltage to the memory when main power is lost. The second regulator also isolates the backup battery from the main 5V supply during normal operation when the memory is being powered by the 5V supply.

A comparator is included which provides automatic switchover from main 5V power to backup power ensuring uninterrupted power for memory and power monitor-

LT, LTC and LT are registered trademarks of Linear Technology Corporation.

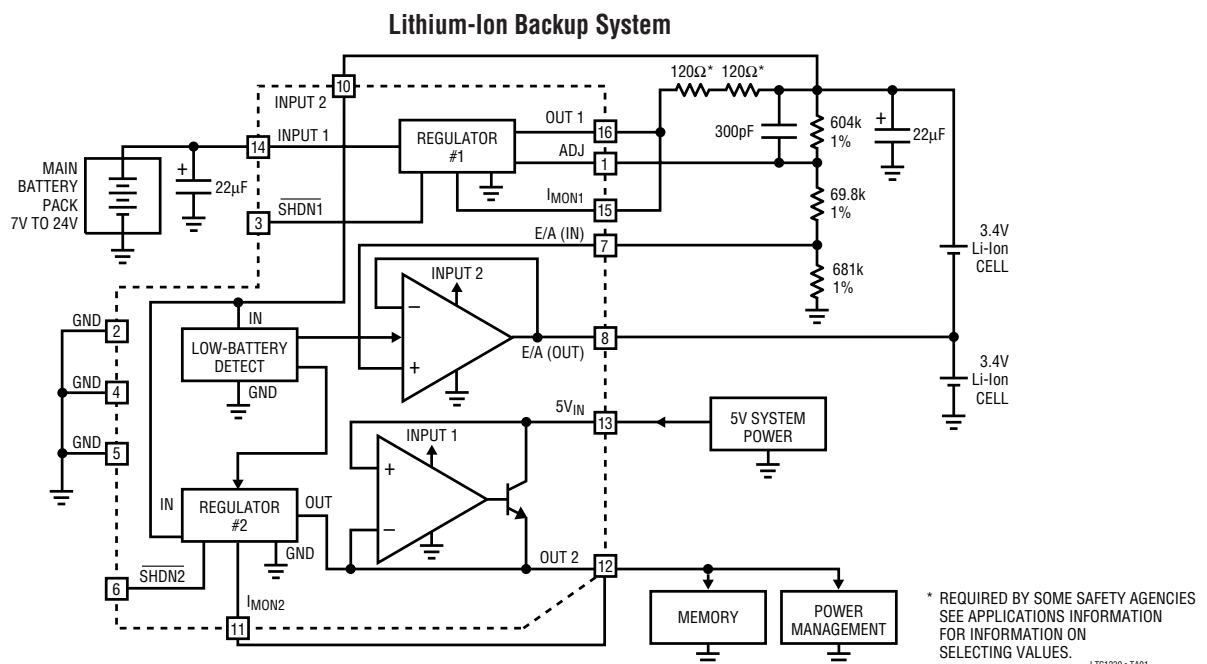
TYPICAL APPLICATION

DESCRIPTION

ing circuitry. A low-battery detector with a 5V threshold powers down the second regulator and the error amplifier to limit the discharge voltage of the backup cells. This

prevents deep discharge damage to the lithium cells. Both regulators have independent shutdown and current monitor functions.

ABSOLUTE MAXIMUM RATINGS

(Note 1)

| | |
|--------------------------|------------|
| Input 1 Voltage | $\pm 30V$ |
| Input 2 Voltage | 30V, -0.6V |
| Output 1 Voltage | 30V, -0.6V |
| Output 2 Voltage | 6V, -0.6V |
| Adjust Pin Current | 10mA |

SHDN1, SHDN2 (Note 2)

| | |
|---------------------|-----------|
| Input Voltage | 6V, -0.6V |
| Input Current | 5mA |

I_{MON1} Voltage

(Note 3) $(V_{IN1} - 30V) < I_{MON1} < V_{IN1}$

I_{MON2} Voltage

(Note 4) $(V_{IN2} - 30V) < I_{MON2} < V_{IN2}$

E/A Output Voltage (Note 5) $-0.6V < V_{E/A(OUT)} < V_{IN2}$

E/A Input Voltage (Note 5) $-0.6V < V_{E/A(IN)} < V_{IN2}$

5V Input Voltage
 6V, -0.6V |

Operating Temperature Range
 0 to 70°C |

Junction Temperature Range
 (Note 6) |

Storage Temperature Range
 -65°C to 150°C |

Lead Temperature (Soldering, 10 sec).....
 300°C |

PACKAGE/ORDER INFORMATION

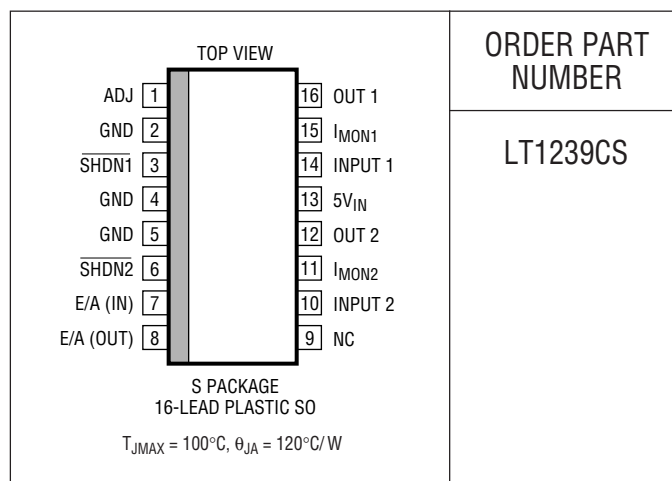

ORDER PART NUMBER

LT1239CS

Consult factory for Industrial and Military grade parts.

ELECTRICAL CHARACTERISTICS

| PARAMETER | CONDITIONS | MIN | TYP | MAX | UNITS |
|---|---|---------|-------|-------|---------|
| Regulator 1 (Notes 7, 8) | | | | | |
| Regulated Output Voltage ($V_{ADJ} = V_{OUT1}$) | $V_{IN1} = 4.3V, I_{OUT} = 1mA, T_J = 25^\circ C$ | 3.700 | 3.750 | 3.800 | V |
| | $V_{IN1} = 4.8V \text{ to } 24V, I_{OUT} = 1mA \text{ to } 30mA$ | ● 3.650 | 3.750 | 3.825 | V |
| Line Regulation | $I_{LOAD} = 1mA, V_{IN1} = 4.3V \text{ to } 30V$ | ● | 2 | 10 | mV |
| Load Regulation | $V_{IN1} = 5V, I_{LOAD} = 1mA \text{ to } 30mA, T_J = 25^\circ C$ | ● | -12 | -25 | mV |
| | $V_{IN1} = 5V, I_{LOAD} = 1mA \text{ to } 30mA$ | ● | -20 | -50 | mV |
| | $V_{IN1} = 5V, I_{LOAD} = 1mA \text{ to } 50mA, T_J = 25^\circ C$ | ● | -20 | | mV |
| | $V_{IN1} = 5V, I_{LOAD} = 1mA \text{ to } 50mA$ | ● | -30 | | mV |
| Dropout Voltage (Note 9) | $I_{LOAD} = 1mA, T_J = 25^\circ C$ | | 0.15 | 0.20 | V |
| | $I_{LOAD} = 30mA, T_J = 25^\circ C$ | | 0.25 | 0.40 | V |
| | $I_{LOAD} = 50mA, T_J = 25^\circ C$ | | 0.30 | | V |
| Ground Pin Current (Notes 10, 11) | $I_{LOAD} = 0mA, V_{IN1} = 3.75V$ | ● | 20 | 30 | μA |
| | $I_{LOAD} = 30mA, V_{IN1} = 3.75V$ | ● | 0.80 | 1.2 | mA |
| | $I_{LOAD} = 50mA, V_{IN1} = 3.75V$ | ● | 1.35 | | mA |
| Adjust Pin Bias Current (Note 12) | $T_J = 25^\circ C$ | | 40 | 120 | nA |

ELECTRICAL CHARACTERISTICS

| PARAMETER | CONDITIONS | | MIN | TYP | MAX | UNITS |
|---|--|---|-------|-------|-------|----------------------|
| Regulator 1 (Notes 7, 8) | | | | | | |
| Shutdown Threshold | $V_{OUT1} = \text{Off to On}$ | ● | | 1.20 | 2.8 | V |
| | $V_{OUT1} = \text{On to Off}$ | ● | 0.25 | 0.75 | | V |
| Shutdown Pin Current (Note 13) | $V_{SHDN1} = 0V$ | ● | | 2 | 4 | μA |
| Quiescent Current in Shutdown (Note 10) | $V_{IN1} = 24V, V_{SHDN1} = 0V$ | ● | | 10 | 16 | μA |
| Ripple Rejection | $V_{IN1} = 5V \text{ (Avg)}, V_{RIPPLE} = 0.5V_{P-P}$ $f_{RIPPLE} = 120\text{Hz}, I_{LOAD} = 20\text{mA}, T_J = 25^\circ\text{C}$ | | 50 | 59 | | dB |
| Current Limit | $V_{IN1} = 7V, V_{OUT1} = 0V, T_J = 25^\circ\text{C}$ | | 30 | 50 | | mA |
| | $V_{OUT1} = V_{OUT1(NOM)} - 100\text{mV}, T_J = 25^\circ\text{C}$ | | 40 | 70 | | mA |
| Reverse Output Current | $V_{OUT1} = 3.75V, V_{IN1} < 3.75V$ | ● | | 6 | 12 | μA |
| | $V_{OUT1} = 3.75V, V_{IN1} = \text{Open Circuit}$ | ● | | 6 | 12 | μA |
| Current Monitor Pin Output Current | $V_{OUT1} = 3.75V, V_{IMON1} = 0V, I_{OUT1} = 1\text{mA}$ | | | 4.6 | | μA |
| | $V_{OUT1} = 3.75V, V_{IMON1} = 0V, I_{OUT1} = 10\text{mA}$ | ● | 38 | 44 | 50 | μA |
| | $V_{OUT1} = 3.75V, V_{IMON1} = 0V, I_{OUT1} = 50\text{mA}$ | | | 215 | | μA |
| Comparator | | | | | | |
| Output Saturation Voltage ($V_{5VIN} - V_{OUT2}$) | $V_{IN1} = 7V, V_{IN2} = 0V, V_{5VIN} = 5V, I_{OUT2} = 1\text{mA}$ | ● | | 12 | 40 | mV |
| | $V_{IN1} = 7V, V_{IN2} = 0V, V_{5VIN} = 5V, I_{OUT2} = 30\text{mA}$ | ● | | 110 | 150 | mV |
| | $V_{IN1} = 7V, V_{IN2} = 0V, V_{5VIN} = 5V, I_{OUT2} = 50\text{mA}$ | ● | | 135 | 220 | mV |
| Low-Battery Detector | | | | | | |
| Turn-Off Threshold | $T_J = 25^\circ\text{C}$ | | 4.85 | 5.00 | 5.15 | V |
| Turn-On Threshold | $T_J = 25^\circ\text{C}$ | | | 5.3 | | V |
| Hysteresis | $T_J = 25^\circ\text{C}$ | | 0.2 | 0.3 | | V |
| Regulator 2 | | | | | | |
| Regulated Output Voltage | $V_{IN2} = 6.8V, I_{OUT} = 1\text{mA}, T_J = 25^\circ\text{C}$ | | 4.775 | 4.850 | 4.925 | V |
| Output Voltage Temperature Coefficient | | | | -0.5 | | mV/ $^\circ\text{C}$ |
| Line Regulation | $I_{OUT2} = 1\text{mA}, V_{IN2} = 5.4V \text{ to } 10V$ | ● | | 2 | 5 | mV |
| Load Regulation | $V_{IN2} = 6.8V, I_{LOAD} = 1\text{mA to } 30\text{mA}, T_J = 25^\circ\text{C}$ | ● | | -12 | -25 | mV |
| | $V_{IN2} = 6.8V, I_{LOAD} = 1\text{mA to } 30\text{mA}$ | ● | | -20 | -50 | mV |
| | $V_{IN2} = 6.8V, I_{LOAD} = 1\text{mA to } 50\text{mA}, T_J = 25^\circ\text{C}$ | | | -20 | | mV |
| | $V_{IN2} = 6.8V, I_{LOAD} = 1\text{mA to } 50\text{mA}$ | | | -30 | | mV |
| Ground Pin Current | $I_{LOAD} = 0\text{mA}, V_{IN2} = 5.4V$ | ● | | 16 | 25 | μA |
| | $I_{LOAD} = 30\text{mA}, V_{IN2} = 5.4V$ | ● | | 0.80 | 1.2 | mA |
| | $I_{LOAD} = 50\text{mA}, V_{IN2} = 5.4V$ | ● | | 1.35 | | mA |
| Shutdown Threshold | $V_{OUT2} = \text{Off to On}$ | ● | | 1.20 | 2.8 | V |
| | $V_{OUT2} = \text{On to Off}$ | ● | 0.25 | 0.75 | | V |
| Shutdown Pin Current | $V_{SHDN2} = 0V$ | ● | | 1.7 | 4 | μA |
| Ripple Rejection | $V_{IN2} = 6.4V \text{ (Avg)}, V_{RIPPLE} = 0.5V_{P-P}$ $f_{RIPPLE} = 120\text{Hz}, I_{LOAD} = 20\text{mA}, T_J = 25^\circ\text{C}$ | | 50 | 58 | | dB |
| Current Limit | $V_{IN2} = 6.8V, V_{OUT2} = 0V, T_J = 25^\circ\text{C}$ | | 30 | 50 | | mA |
| | $V_{OUT2} = V_{OUT2(NOM)} - 100\text{mV}, T_J = 25^\circ\text{C}$ | | 40 | 70 | | mA |
| Reverse Output Current | $V_{OUT2} = 4.85V, V_{IN2} < 4.85V$ | ● | | 6 | 12 | μA |
| | $V_{OUT2} = 4.85V, V_{IN2} = \text{Open Circuit}$ | ● | | 6 | 12 | μA |
| Current Monitor Pin Output Current | $V_{OUT2} = 6.8V, V_{IMON2} = 0V, I_{OUT2} = 1\text{mA}$ | | | 4.7 | | μA |
| | $V_{OUT2} = 6.8V, V_{IMON2} = 0V, I_{OUT2} = 10\text{mA}$ | ● | 35 | 41 | 47 | μA |
| | $V_{OUT2} = 6.8V, V_{IMON2} = 0V, I_{OUT2} = 50\text{mA}$ | | | 210 | | μA |
| Error Amplifier | | | | | | |
| Bias Current | $V_{E/A(IN)} = 3.4V, V_{IN2} = 6.8V$ | ● | | 3 | 20 | nA |

ELECTRICAL CHARACTERISTICS

| PARAMETER | CONDITIONS | MIN | TYP | MAX | UNITS |
|--|---|-----|-----|-----|---------|
| Offset Voltage | ● | | 0 | 15 | mV |
| Output Current Sourcing | $V_{IN2} = 6.8V, V_{E/A(IN)} = 3.4V, T_J = 25^\circ C$ | 3 | 5 | | mA |
| Output Current Sinking | $V_{IN2} = 6.8V, V_{E/A(IN)} = 3.4V, T_J = 25^\circ C$ | 3 | 5 | | mA |
| Regulator 2, Low Battery Detector and Error Amplifier | | | | | |
| Quiescent Current | $V_{IN2} = 6.8V, 5V_{IN} = 0V, V_{E/A(IN)} = 3.4V$ | ● | 20 | 30 | μA |
| | $V_{IN2} = 6.8V, 5V_{IN} = 0V, V_{E/A(IN)} = 3.4V, V_{PIN6} = 0V$ | ● | 8 | 12 | μA |
| | $V_{IN2} = 4.8V, 5V_{IN} = 0V, V_{E/A(IN)} = 2.4V$ | ● | 3 | 6 | μA |

The ● denotes specifications which apply over the full operating temperature range.

Note 1: All voltages are with respect to the ground pins of the device (pins 2, 4, 5) unless otherwise specified.

Note 2: The shutdown pin input voltage rating is required for a low impedance source. Internal protection devices connected to the shutdown pin will turn on and clamp the pin to approximately 7V or -0.6V. This range allows the use of 5V logic devices to drive the pin directly. For high impedance sources or logic running on supply voltages greater than 5.5V, the maximum current driven into the shutdown pin must be limited to 5mA.

Note 3: The current monitor pin for regulator 1 (pin 15) can be pulled 30V below the input pin (pin 14). The current monitor pin must not be pulled above the input pin.

Note 4: The current monitor pin for regulator 2 (pin 11) can be pulled 30V below the input pin (pin 10). The current monitor pin must not be pulled above the input pin.

Note 5: E/A (OUT) pin should not be pulled below ground or above the voltage at Input 2.

Note 6: The device is specified to an operating temperature range of 0°C to 70°C. The device is guaranteed to be functional up to the thermal shutdown temperature. The thermal shutdown temperature for this device is approximately 100°C.

Note 7: Operating conditions are limited by maximum junction temperature. The regulated output specification will not apply for all possible combinations of input voltage and output current. When operating at maximum output current, the input voltage range must be limited. When operating at maximum input voltage, the output current range must be limited.

Note 8: Regulator 1 of the LT1239 is tested and specified with the adjust pin (pin 1) tied to the output pin (pin 16). See Applications Information.

Note 9: Dropout voltage is the minimum input/output voltage required to maintain regulation at the specified output current. In dropout, the output voltage measured at the package pins will be equal to $(V_{IN} - V_{DROPOUT})$.

Note 10: The quiescent current of the comparator is included in the ground pin current and quiescent current specifications for regulator 1. The comparator output is turned off (pin 13 = 0V, pin 12 = 5V) during these tests.

Note 11: Ground pin current for regulator 1 is tested with $V_{IN} = V_{OUT}$ (nominal) and a current source load. This means that the device is tested in its dropout region. Ground pin current will decrease slightly at higher input voltages.

Note 12: Adjust pin current flows into the adjust pin.

Note 13: Shutdown pin current at $V_{SHDN} = 0V$ flows out of the shutdown pin.

Note 14: 6.8V is the nominal voltage of two lithium-ion cells.

TYPICAL PERFORMANCE CHARACTERISTICS

Low-Battery Detector Thresholds vs Temperature

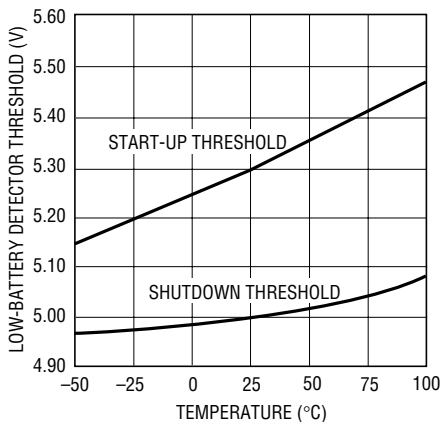

LT1239 • TPC01

Regulator 2 Output Voltage vs Temperature

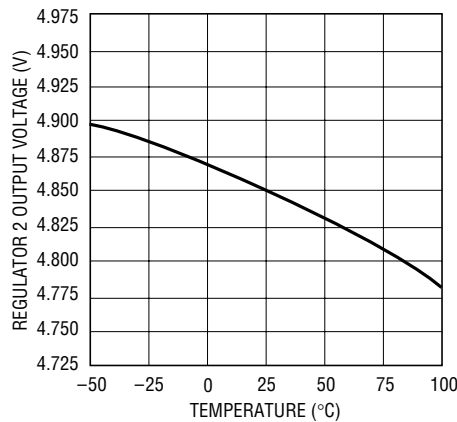

LT1239 • TPC02

Regulator 1 Adjust Pin Voltage vs Temperature

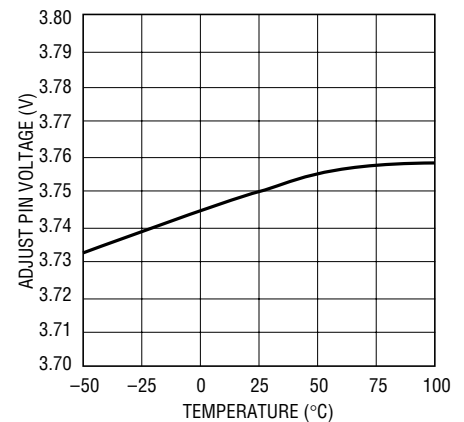

LT1239 • TPC03

TYPICAL PERFORMANCE CHARACTERISTICS

Regulator 2 I_{MON2} Current vs Output Current

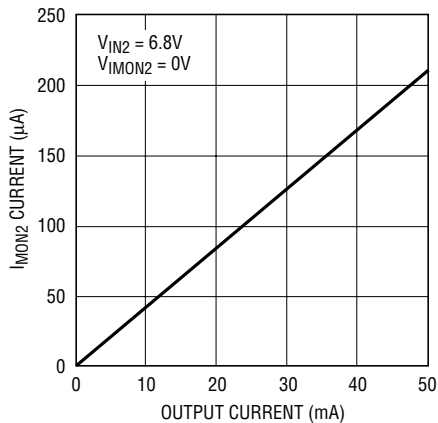

LT1239 • TPC04

Regulator 1 I_{MON} Current vs Output Current

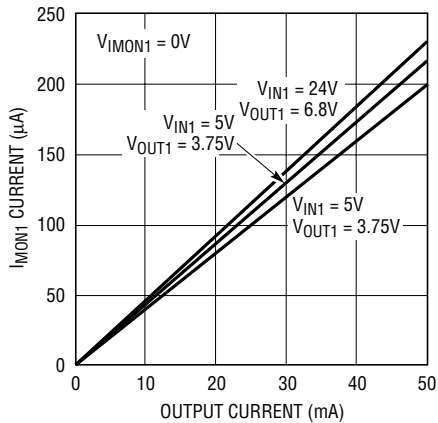

LT1239 • TPC05

Regulator 1, Comparator Quiescent Current vs Input Voltage, Pin 14

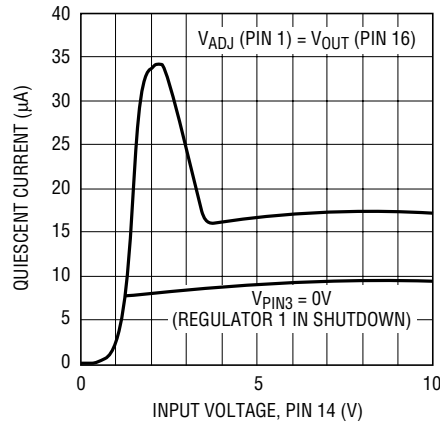

LT1239 • TPC06

Comparator Output Saturation Voltage vs Output Current

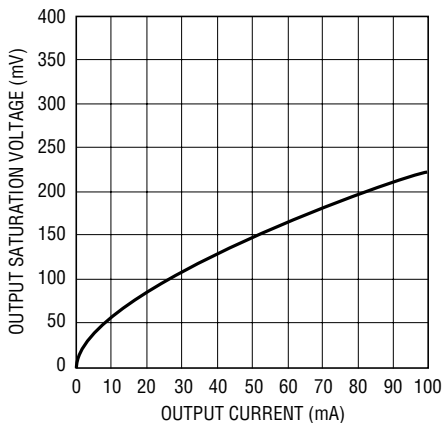

LT1239 • TPC07

Regulator 1 Reverse Output Current vs Output Voltage

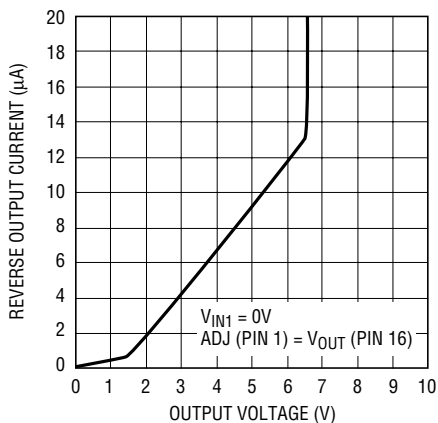

LT1239 • TPC08

Regulator 2 Reverse Output Current vs Output Voltage

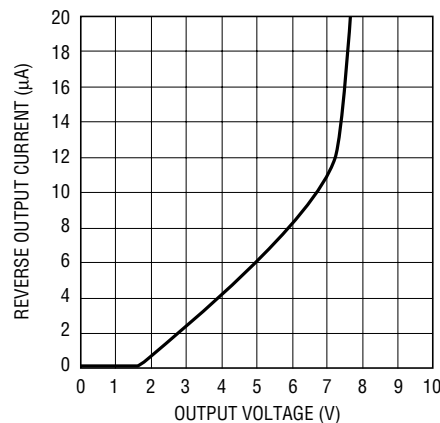

LT1239 • TPC09

Shutdown Pin Threshold

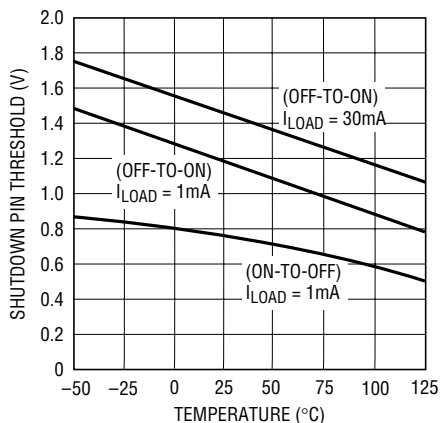

LT1239 • TPC10

Regulator 2, Error Amp, Low-Battery Detector Quiescent Current

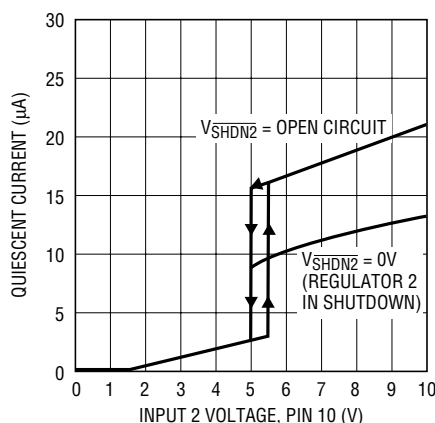

LT1239 • TPC11

PIN FUNCTIONS

ADJ (Pin 1): Adjust Pin of Regulator 1. The regulator will servo the adjust pin to 3.75V referred to ground. Bias current will be approximately 50nA and will flow into the adjust pin.

GND (Pin 2): Ground Pin for Regulator 1. Note that the three ground pins (pins 2, 4, 5) are connected together internally and should all be grounded externally.

SHDN1 (Pin 3): Shutdown Pin for Regulator 1. Regulator 1 output will be on if the shutdown pin is either: 1) Left floating (open circuit) or 2) pulled up to the 5V rail. If the shutdown function is not used, the shutdown pin is normally left open circuit. Regulator 1 output will be off if the shutdown pin is pulled to ground. The shutdown pin current with the pin pulled to ground will be in the range of 2 μ A flowing out of the pin. The shutdown pin current with the pin pulled up to 5V will be zero.

GND (Pin 4): Ground. This ground pin is tied to the substrate of the die, between regulator 1 and the rest of the circuit. It is used as an isolation barrier between regulator 1 and the rest of the circuitry.

GND (Pin 5): Ground Pin for Regulator 2.

SHDN2 (Pin 6): Shutdown Pin for Regulator 2. Regulator 2 output will be on if the shutdown pin is either: 1) Left floating (open circuit) or 2) pulled up to the 5V rail. If the shutdown function is not used, the shutdown pin is normally left open circuit. Regulator 2 output will be off if the shutdown pin is pulled to ground. The shutdown pin current with the pin pulled to ground will be in the range of 2 μ A flowing out of the pin. The shutdown pin current with the pin pulled up to 5V will be zero.

E/A (IN) (Pin 7): Noninverting Input of the Error Amplifier. This pin should be tied to the center tap point in the output divider for regulator 1. The bias current for this pin will be in the range of 3nA and it will flow out of the pin.

E/A (OUT) (Pin 8): Output of the Error Amplifier. This is normally connected to the center tap of the backup cells.

NC (Pin 9): Not Connected.

INPUT 2 (Pin 10): Input Pin (V_{CC}) for Regulator 2, the Error Amplifier, and the Low-Battery Detection Circuit.

I_{MON} 2 (Pin 11): Current Monitor Pin for Regulator 2. If the current monitor function is not used, this pin should be tied to the output pin of regulator 2.

OUT 2 (Pin 12): Output of Regulator 2. It is also the inverting input and output of the comparator. If the main 5V system supply is up and running then the comparator output will pull the output of regulator 2 up to 5V.

5V_{IN} (Pin 13): Noninverting Input of the comparator and the collector of the output driver. The collector of the output driver is normally connected to the main 5V system supply.

INPUT 1 (Pin 14): Input Pin (V_{CC}) of Regulator 1.

I_{MON} 1 (Pin 15): Current Monitor Pin for Regulator 1. The current flowing out of this pin will be approximately 1/200 of the output current of regulator 1. If the current monitor function is not used, this pin should be tied to the output pin of regulator 1.

OUT 1 (Pin 16): Output of Regulator 1.

FUNCTIONAL DESCRIPTION

Regulator 1: Regulator 1 is used to supply the charging current to the backup batteries. It converts the voltage on the main battery to a fixed output voltage to charge the backup cells. The output voltage is set with a voltage divider connected between the output and ground with a tap point of the divider connected to the adjust pin. The regulator servos its output in order to maintain the adjust pin at 3.75V referred to ground. The resistor divider should be chosen such that the divider current is approxi-

mately 5 μ A. This means the impedance from the adjust pin to ground should be approximately 750k Ω . For safety requirements a resistor can be placed between the output pin and the top of the divider that sets the regulated output voltage. The regulator will regulate the voltage at the top of the divider. Quiescent current will be 10 μ A to 15 μ A. Output short-circuit current will be approximately 70mA.

FUNCTIONAL DESCRIPTION

Comparator: The output of the comparator is connected to the output of regulator 2. This point provides power to memory and power management circuitry. The comparator looks at the main 5V power line and the output voltage of regulator 2. If the main 5V line is up and regulating the comparator output will pull up to 5V and supply power to the memory from the main 5V regulator. If the main 5V power line drops below 4.85V the comparator switches off and regulator 2 will supply power to the memory from the backup batteries. The comparator is powered from the raw battery voltage at the input of regulator 1.

Error Amplifier: The Error Amplifier is used to equalize the cell voltages of two lithium-ion cells connected in series. The error amplifier is designed to source or sink 5mA.

Low-Battery Detector: The low-battery detector circuit acts as an undervoltage lockout. This circuit turns regulator 2 and the error amplifier off if the backup battery voltage drops below 5V. The low-battery detector circuit will turn regulator 2 and the error amplifier back on when the backup battery voltage rises above 5.3V. This circuit has a quiescent current of approximately 3 μ A in the undervoltage condition.

Regulator 2: Regulator 2 is used to regulate the voltage of the backup batteries and isolate the backup batteries from the main 5V line. This regulator will prevent reverse current flow from the main 5V supply back into the backup cells.

BLOCK DIAGRAM

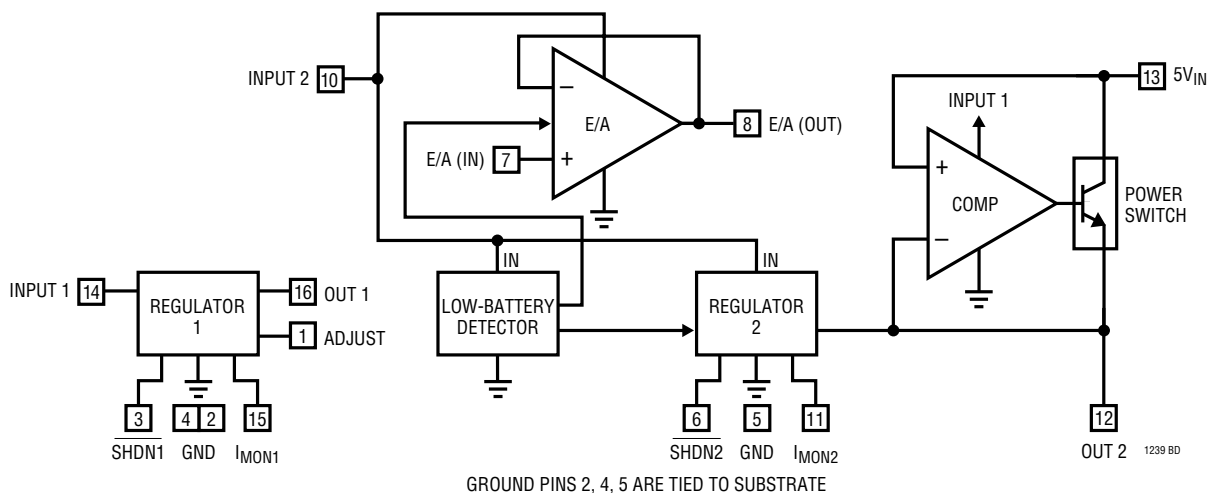

APPLICATIONS INFORMATION

Device Overview

The LT1239 provides several functions needed for backup battery management. It provides:

1. Battery Charging: The LT1239 can be set up to charge lithium-ion or nickel cadmium batteries in either constant voltage or constant current mode.
2. Memory Power Control: The LT1239 provides power for the memory and includes automatic switchover

between the backup battery and the main 5V system power. When the 5V system supply is up and running it is used to power the memory, the regulator prevents reverse current flow back into the backup battery. Automatic switchover occurs when the 5V system supply drops below 4.85V and the regulator then provides power to the memory from the backup cells. Memory power is uninterruptable.

APPLICATIONS INFORMATION

- Protection: Regulator 1 allows the use of current limiting resistors to prevent overcharging lithium-ion cells. A low-battery detector shuts down regulator 2 and the error amplifier to prevent over discharging the lithium cells. An error amplifier is included to provide voltage equalization for two series connected lithium-ion cells.

Adjusting Output Voltage

Regulator 1 is an adjustable regulator. This allows the output voltage to be set for various battery types and voltages. The output voltage is adjustable from 3.75V up to 20V. The regulator will servo its output voltage in order to maintain the adjust pin at 3.75V with respect to ground. The output voltage is set with a resistor divider from output to ground as shown in Figure 1. The resistor values should be chosen so that the current in the divider is approximately 5μA. This means that the impedance from the adjust pin to ground should be approximately 750kΩ. The bias current at the adjust pin is 50nA (typical) and will flow into the adjust pin. The error in the output voltage, due to the adjust pin bias current will be equal to the bias current multiplied by the value of R2 ($I_{ADJ} \times R2$). This error is small and is compensated for in the formulas shown in Figure 1.

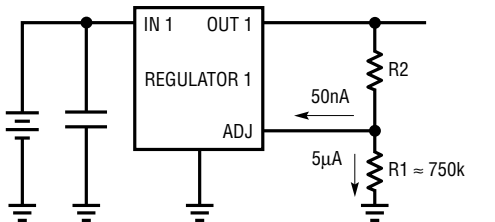

$$V_{OUT} = 3.75 \left(1 + \frac{R2}{R1} \right) + I_{ADJ} (R2)$$

$$R2 = \frac{(V_{OUT} - 3.75V)}{(3.75V/R1) + I_{ADJ}}$$

CHOOSE: $R1 = 750k$
 $I_{ADJ} = 50nA$

LT1239 • F01

Figure 1. Adjusting Output Voltage

Example: To set the output voltage to 6.8V for a 2-cell lithium-ion system, use $R1 = 750k$ and $I_{ADJ} = 50nA$.

Then:

$$R2 = \frac{6.8V - 3.75V}{(3.75V/750k) + 50nA} = 604k$$

Equalizing Lithium-Ion Cells

The error amplifier on the LT1239 is used to equalize the cell voltages in a 2-cell lithium-ion backup system. The error amplifier is internally connected as a unity-gain follower and is designed to sink or source about 3mA. The bias current for the error amplifier will be approximately 3nA and will flow out of the pin. The output voltage of the error amplifier can be set by connecting the input to a tap point on the resistor divider used to set the output voltage for regulator 1 as shown in Figure 2. The error amplifier will then equalize the cell voltages by charging the cell with the lowest output voltage. The output voltage of regulator 1 controls the total cell voltage and the error amplifier forces the cell voltages to be equal. The error amplifier output current will go to zero when the cell voltages are equal and the total cell voltage is equal to the output voltage of regulator 1.

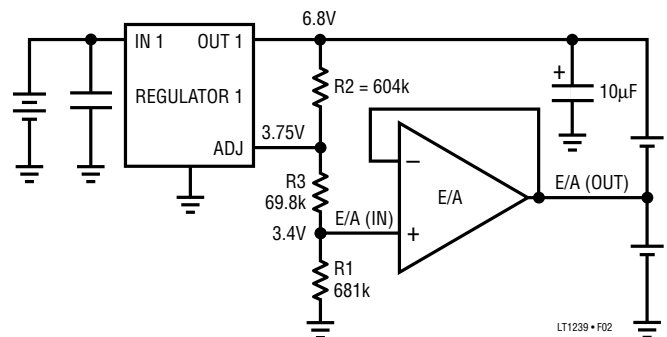

LT1239 • F02

Figure 2. Equalizing Lithium-Ion Cells

For battery voltages greater than the low-battery detection threshold the error amplifier is active. For battery voltages lower than the low-battery detection threshold the output of the error amplifier is inactive. When the error amplifier is active it can source or sink approximately 3mA. When the error amplifier is inactive its output is a high impedance, as long as it is not forced above V_{IN2} or below ground.

The error amplifier is powered from the same supply pin as regulator 2. In most applications the backup batteries and the output of regulator 1 will provide power to this point. This means that the protection resistors ($R4$ in Figure 5) in series with the output of regulator 2 will limit the output current capability of the error amplifier in a fault condition.

APPLICATIONS INFORMATION

Using the Current Monitor Function

The current monitor pin outputs a current proportional to the output current of the regulator. Both regulator 1 and regulator 2 have independent current monitor pins. The current monitor function can be used to monitor charge in the backup cells, to set up a constant current output or to adjust the current limit of the regulator. The current monitor pin should be tied to the output pin if the current monitor function is not used. This will minimize quiescent current.

The current output of the current monitor pin can be converted to a voltage by feeding the current monitor pin output current through a resistor. The voltage across the resistor will be proportional to output current. This signal can be used to monitor the output current for either regulator. Regulator 1 output current is equal to the charge current for the backup batteries plus the load current of regulator 2. If regulator 1 output current is greater than regulator 2 output current, the difference between the currents is the charge current for the backup cells. If regulator 2 output current is greater than regulator 1 output current, the difference between the currents is the discharge current for the backup cells. By integrating the difference between regulator 1 output current and regulator 2 output current the total charge in the backup cells can be determined.

Constant Current Charging

NiCd backup batteries are normally charged with a constant current trickle charge. This can be accomplished

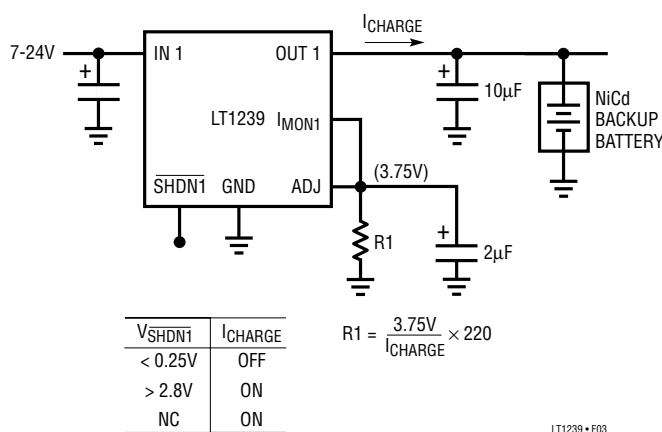

Figure 3. Constant Current Charging

using regulator 1 and the circuit shown in Figure 3. In this circuit the voltage at the adjust pin is proportional to the output current. Regulator 1 will servo its output to force 3.75V at the adjust pin. The output current will be scaled from the current monitor pin current by a ratio of 220:1. Output current is equal to $220 \times$ current monitor pin current. The output current is set by choosing resistor R1, in the formula shown in Figure 3. Regulator 1 will source a constant current as long as the voltage at its input is greater than the battery voltage plus the dropout voltage of regulator 1. External power monitoring circuitry can be used to shutdown regulator 1 to terminate charge when a low current sleep mode is desired.

Setting Current Limit Using the Current Monitor Pin

With the addition of some simple external circuitry the current monitor pin can be used to control the output short-circuit current of the regulator. As shown in Figure 4, the current monitor pin can be tied to ground through a resistor to generate a voltage proportional to output current. When the voltage across R3 is equal to approximately 0.6V (one V_{BE}) Q1 will turn on and pull down on the shutdown pin of the regulator. Q1 effectively steals drive current from the regulator to limit the output current. C1 is needed to roll off the gain of Q1. Current limit can be set using the formula shown in Figure 4. This circuit can be used with either regulator. The shutdown function can also be used. An open-collector gate connected in parallel with Q1 can shut down the regulator.

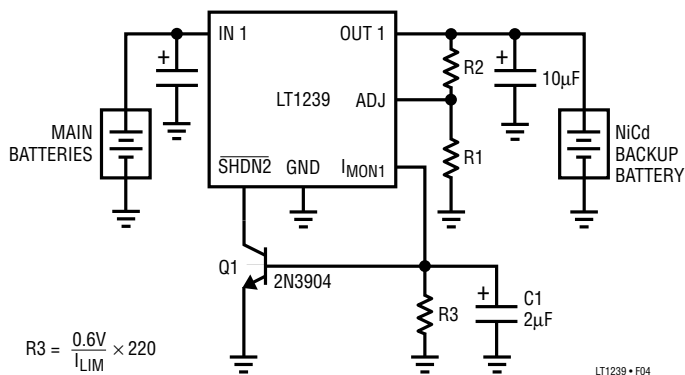

Figure 4. Reducing Current Limit

Using the Comparator

The comparator in the LT1239 is intended to be used as an automatic switchover circuit between the main 5V

APPLICATIONS INFORMATION

system power and the backup batteries. The comparator output will be driven high if the output of the 5V system supply is greater than the 4.85V output of regulator 2. Regulator 2 will act as a diode to prevent current flow from the 5V system supply back into the backup battery. Current flow into the output of regulator 2, with the output pulled up to 5V, will be limited to approximately 6 μ A and will flow to ground. If the main 5V system supply drops below the 4.85V output of regulator 2 the comparator will switch off and regulator 2 will provide power to the memory. The comparator combined with regulator 2 and the batteries provide an uninterruptable power source to the memory and power monitoring circuitry.

Choosing Current Limiting Resistors

Due to UL safety considerations, circuits used to charge lithium-ion batteries must have external resistors (passive components) to limit the available charge current in the event of a failure in the charging circuit. The LT1239 allows these resistors to be placed in series with the output transistor of the regulator 1 as shown in Figure 5. The current limiting resistor (R4) will be in series with the main charge current path but will be inside the feedback loop of regulator 1. Because the resistors are inside the feedback loop they will not affect output voltage regulation in normal operating conditions. The resistors should be selected so that they limit the charge current below the maximum level specified by the battery manufacturer. For a typical 3.4V, 50mA rechargeable backup cell (Panasonic VL2330) the maximum charge current is specified at 300mA. Most users will choose to limit the current well below the maximum charge current. It is important to note that these resistors can also limit the charge current during normal operation. Since the charge current for a typical lithium-ion button cell is normally less than 20mA, limited by the internal impedance of the cells during a constant voltage charge, the current limiting resistors do not significantly affect the charge times for the backup cells. The worst case would occur if the regulator failed as a short and the main battery is at its maximum charge voltage. The current limiting resistor (R4) must be chosen to limit the current to less than the manufacturers maximum charging current with the difference between the main battery voltage and the backup battery voltage dropped across it.

For example with a main battery voltage of 24V max, a backup battery voltage of 6.8V and a maximum charge current of 300mA, R4 must be greater than $(24V - 6.8V) / 300mA$, $R4 > 57\Omega$.

R4 can also be used to limit the power dissipated by regulator 1 as shown in the following section. C1 is needed for stability in circuits with protection resistors (R4).

The power dissipation in R4 during fault conditions can be significant. it will be equal to:

$$\frac{(V_{INL} - V_{BATTERY})^2}{R4}$$

Power resistors with ratings greater than 0.25W or fusible resistors may be required.

Thermal Considerations

The power dissipation of this device is made up of several components. They are the power dissipation of each regulator, the comparator and the error amplifier. The largest component will be due to the power in regulator 1, when the charge current for the batteries is the highest and the input voltage to regulator 1 is at the maximum. In most systems this condition only occurs for a short period after the backup battery has been completely discharged. Both regulators have thermal limiting circuitry which limits the power in the regulator when the junction temperature reaches about 100°C. The thermal limit temperature is set low because the device is designed to work with batteries specified to run at ambient temperatures below 60°C. The power in regulator 1 can be limited with external resistors placed in the feedback loop as shown in Figure 5. In lithium-ion systems these resistors are required for safety reasons.

The power in regulator 1 will be equal to:

$$[(V_{MAINBATTERY} - V_{BACKUPBATTERY}) \times I_{CHG}] - (I_{CHG} \times R4)$$

Note that for circuits with a current limiting resistor (R4) the worst-case power point occurs when I_{CHG} is equal to the maximum charging current/2.

$$\text{Example: } [(24V - 6.8V) \times (71mA/2)] - [(71mA/2) \times 240] \\ = 300mW$$

This is the only significant component of power dissipation in the device and this condition will only occur when the

APPLICATIONS INFORMATION

backup batteries have been completely discharged. Once the backup batteries are charged the power in regulator 1 drops significantly. The power in regulator 2 when regulator 2 is providing power to the memory will be equal to:

$$(V_{\text{BACKUPBATTERY}} - 4.85\text{V}) \times I_{\text{OUT}}$$

I_{OUT} is the current needed to power the memory and power monitoring circuitry.

$$\text{Example: } (6.8\text{V} - 4.85\text{V}) \times 30\text{mA} = 58.5\text{mW}$$

The power in the comparator when the comparator is providing power to the memory will be equal to:

$$(V_{\text{SAT}} \times I_{\text{OUT}})$$

I_{OUT} is the current needed to power the memory and power monitoring circuitry. Comparator Output Saturation Voltage vs Output Current can be found in the Typical Performance Characteristics.

$$\text{Example: } (V_{\text{SAT}} \times I_{\text{LOAD}}) = (0.15\text{V} \times 30\text{mA}) = 4.5\text{mW}$$

Note that power for memory will be supplied by either regulator 2 or the comparator. The power in the error amplifier when the cells are unequalized will be equal to:

$$(V_{\text{BACKUPBATTERY}}/2) \times 3\text{mA}$$

$$\text{Example: } (6.8\text{V}/2) \times 3\text{mA} = 10.2\text{mW}$$

This component goes to zero when the cell voltages are equalized.

The thermal resistance of the LT1239 is $120^{\circ}\text{C}/\text{W}$ when the device is mounted to a PC board with at least one ground or power plane. The junction temperature rise will be equal to the total power in the device multiplied by $120^{\circ}\text{C}/\text{W}$ or $(P_{\text{TOTAL}} \times 120^{\circ}\text{C}/\text{W})$. For 300mW dissipation the junction temperature rise will be $(300\text{mW} \times 120^{\circ}\text{C}/\text{W}) = 36^{\circ}\text{C}$. Given that the thermal limit temperature is approximately 100°C , this allows for a maximum ambient temperature of roughly 60°C before the device thermal limits. This temperature is near the maximum ambient allowed for most battery types.

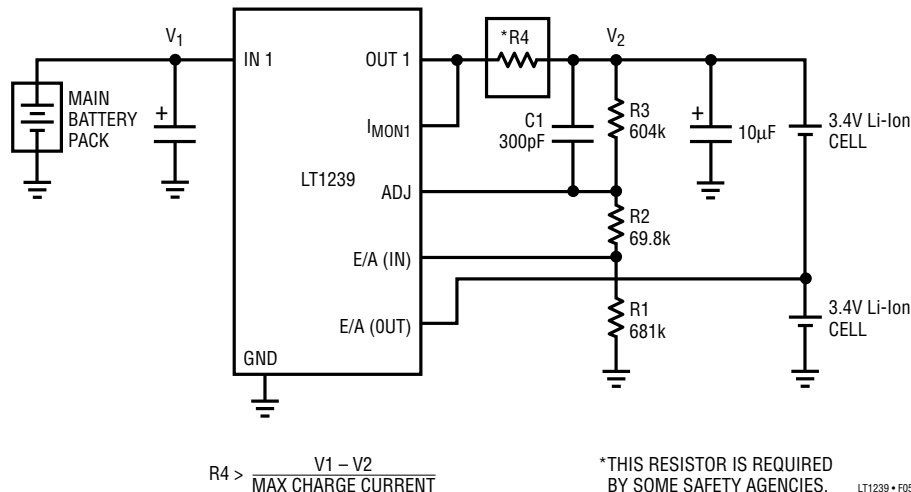
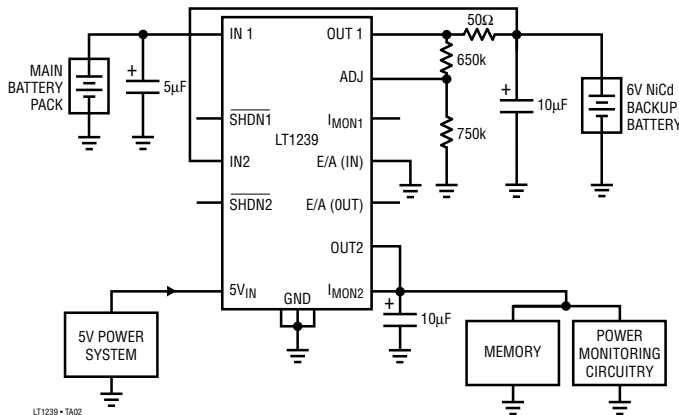

Figure 5. Adding a Protection Resistor for Lithium-Ion Charger

TYPICAL APPLICATIONS

NiCd Backup System with 20mA Charge Current



NiCd Backup System with 5mA Trickle Charge

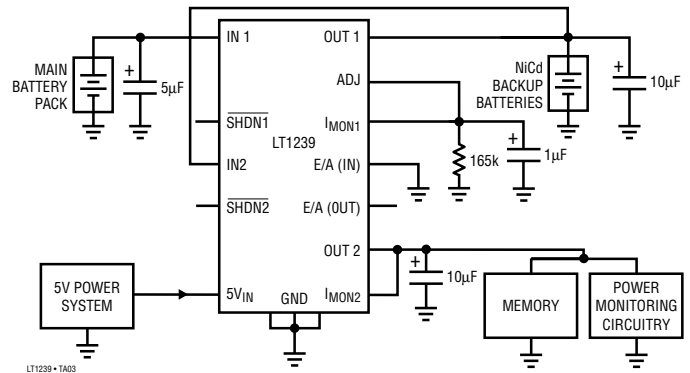

PACKAGE DESCRIPTION

Dimension in inches (millimeters) unless otherwise noted.

S Package 16-Lead Plastic DIP

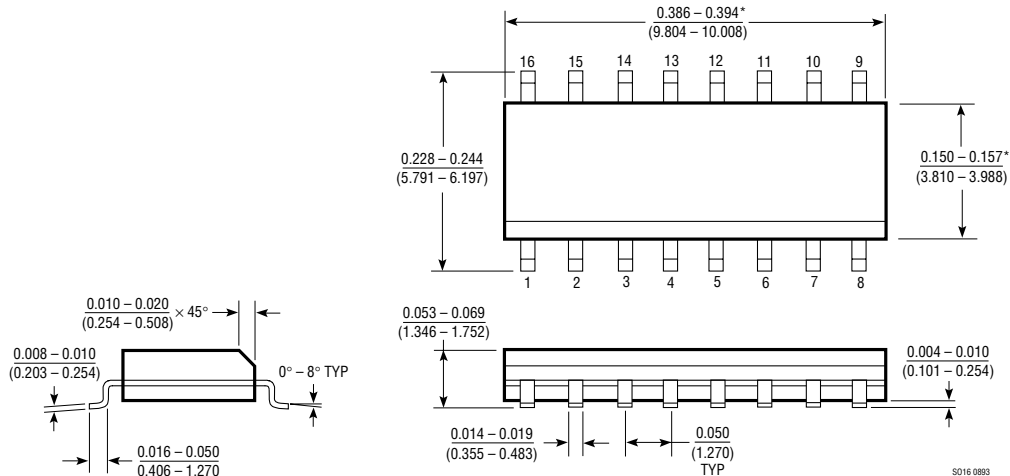

*THESE DIMENSIONS DO NOT INCLUDE MOLD FLASH OR PROTRUSIONS.
MOLD FLASH OR PROTRUSIONS SHALL NOT EXCEED 0.006 INCH (0.15mm).

RELATED PARTS

| PART NUMBER | DESCRIPTION | COMMENTS |
|-------------------------|--|--|
| LT1111 | Micropower DC/DC Converter with Adjustable or Fixed 5V or 12V Output | Low-Battery Detector |
| LT1120A | Micropower Regulator and Comparator with Shutdown | 20μA Supply Current |
| LT1121 | Micropower Regulator with Shutdown | 0.4V Dropout Voltage at 150mA |
| LTC®1232 | Microprocessor Supervisory Circuit | Minimum External Components |
| LTC1325 | Microprocessor-Controlled Battery Management System | Charges Battery and Provides Gas Gauge |
| LTC1443/LTC1444/LTC1445 | Quad Micropower Comparators with Reference | 6μA Quiescent Current |
| LT1510 | Programmable PWM Battery Charger with 2A Peak Current Capability | Charges NiCd, NiMH |